

Education for Embedded System



Name	USHIIMARU Shinji	E-mail	ushimaru@numazu-ct.ac.jp
Job Title	Professor	Degree	Doctor of Science
Academic Society and Association	Information Processing Society of Japan		
Research Keywords	Raspberry Pi , Arduino, Embedded System		
Technical Fields and Topics possible for collaboration	<ul style="list-style-type: none"> Education for Embedded System using Raspberry Pi and Arduino Control of motor, encoder and various sensors Design of embedded software 		

Details of the Research Theme

Raspberry Pi and Arduino, which are inexpensive, easily available, and have a lot of information, have been widely used as introductory education for embedded systems. Techniques can be provided based on the experience of introducing these into actual education.

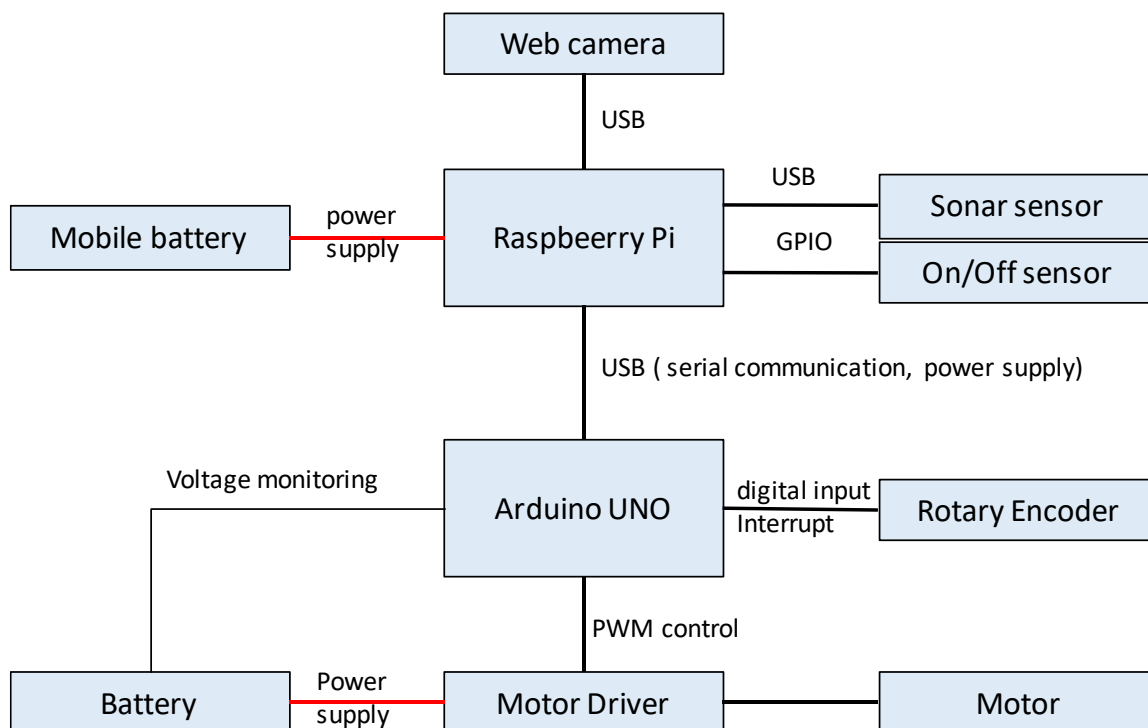

Structure of Autonomous Moving System using Raspberry Pi and Arduino (Example)

Development of machine learning model embedded microcomputer IoT system



Name	Jeong, ManYong	E-mail	jeong@numazu-ct.ac.jp
Job Title	Professor	Degree	Doctor of Engineering
Academic Society and Association	Japan Society of Mechanical Engineers (JSME), Information Processing Society of Japan (IPSJ)		
Research Keywords	Nonlinear Vibration, Machine Learning, Deep Learning, Traffic Engineering, Computer Vision		
Technical Fields and Topics possible for collaboration	Edge computing system (Using microcomputers, such as Jetson nano, Raspberry pie, Arduino and LattePanda, sensing technique, application of wearable device etc.), Machine Learning, Deep Learning		

Details of the Research Theme

Researches in our lab focus on two intimately connected branches of computer vision and edge computing. In both fields, we are interested in applications of deep learning techniques for object recognition, scene categorization, human motion recognition etc. and machine learning techniques for state analysis of human body, human motion recognition, abnormal diagnosis etc.

Development of traffic simulation system: The simulation technology plays a key role in developing Intelligent Transportation System 'ITS'. We aspire to develop simulation systems with high-forecasting ability traffic flow data and help intersection agent control the traffic signal efficiently. Intersection agents collaborate on controlling properly all the traffic situation on those intersections based on data being collected by the computer vision systems. The traffic data measurement systems are using fixed point cameras and drive recorders and the computer vision system is employing CNN.



Fixed point cameras equipped in two intersections

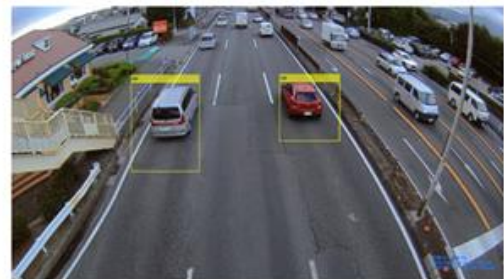

Vehicle detection system by CNN

Development of edge computing systems: Edge computing is a distributed computing paradigm which brings computation and data storage closer to the location where it is needed, to improve response times and save bandwidth. We aspire to develop edge computing systems using single board computer and various sensors, and those systems help the things or the machineries correspond to their situations and emergency.

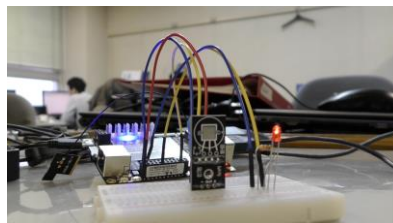

Edge computing system



Analysis of non-linear vibration behavior: A lot of problems still remain to be done in nonlinear vibration field such as rocking and rotational vibration, new approaches are needed to obtain the better solutions and the neural network is one of those. For example, The neural network with suitable selection of system inputs and outputs are Applicable for system identification of nonlinear vibration by learning of response.

Regional theme: Examples using machine learning, geographic information system, and social big data



Name	SUZUKI Shizuo	E-mail	shizuo.suzuki@numazu-ct.ac.jp
Job Title	Associate professor	Degree	Ph. D
Academic Society and Association	GIS Association of Japan. The Society of Eco-Engineering		
Research Keywords	Remote sensing,, Machine learning, GIS, Social big data		
Technical Fields and Topics possible for collaboration	Acquisition and analysis of data on agriculture, forestry, and tourism using remote sensing technology and machine learning		

Details of the Research Theme

I will work with local people on topics that are closely related to the region, mainly in eastern parts of Shizuoka Prefecture, Mt. Fuji, Hakone region and Izu Peninsula.

The figure on the left is a tea garden taken from above with a digital camera. The figure on the right is a map that estimates the percentage of new leaves at the same location using remote sensing technology. This makes it possible to determine where tea leaves have high growth rates over a wide area.

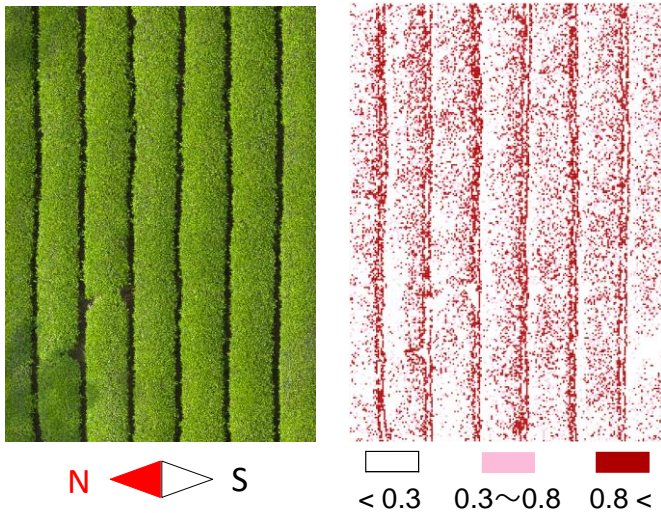

The left figure is an aerial photograph of a bamboo forest. The green part in the right figure is the bamboo forest extracted from aerial photographs using machine learning. In both figures, the red line indicates the bamboo forest edge.

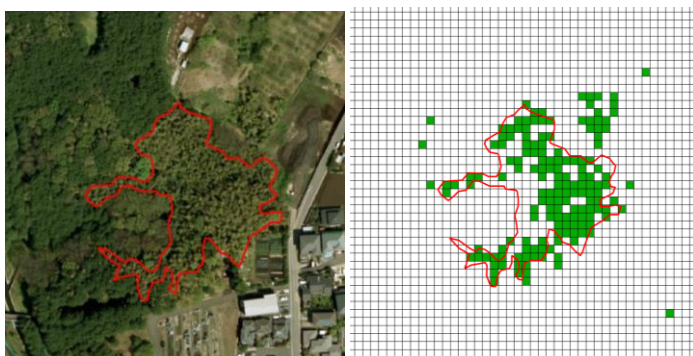

Maps that shows the shooting locations such as scenery from Flickr, a photo sharing site that is one of the SNSs, according to the number of shots. The upper and lower figures indicate Japanese and foreigners, respectively. The maps show the results of four years after Mt. Fuji was registered as a World Cultural Heritage. To use social big data in this way is one of the tools for investigating the trend of tourists.

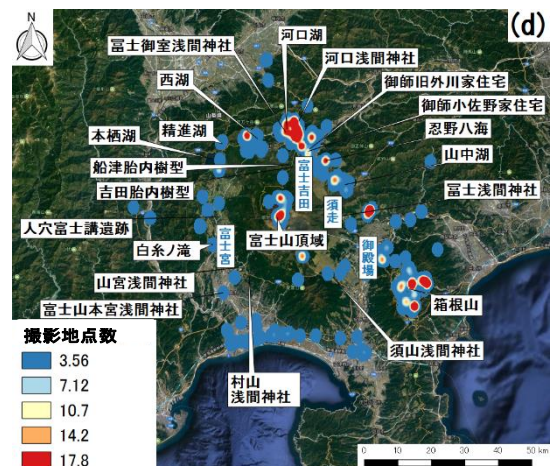
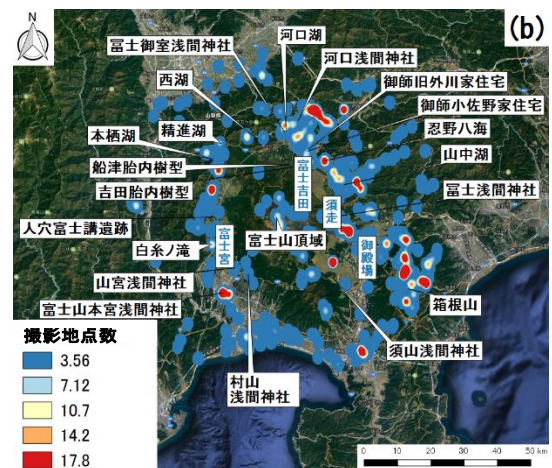

Development of thermal fluid measurement system by using embedded device



Name	OHBA Katsuhisa	E-mail	ooba@numazu-ct.ac.jp
Job Title	Associate Professor	Degree	Doctor of Engineering
Academic Society and Association	The Japan Society of Mechanical Engineers, The Japan Society of Fluid Mechanics, The Institute of Electronics, Information and Communication Engineers		
Research Keywords	Fluid Engineering, Wind Tunnel Experiment, FPGA device		
Technical Fields and Topics possible for collaboration	<ul style="list-style-type: none"> Technique of wind tunnel experiment and fluid measurement Development of thermal fluid measurement system by using embedded device (FPGA) and LabVIEW 		

Details of the Research Theme

Main theme of this laboratory is the experimental research on heat and momentum transfer in a stably stratified mixing layer through a wind tunnel experiment. Utilizing digital technology, a thermal fluid measurement which previously required specialized knowledge and skills has been facilitated. By combining mechanical engineering, electrical and electronic engineering, and information processing technology, the thermal fluid measuring instrument and the multi-point measurement system have been developed.

When evaluating the performance of various types of thermal equipment, it is important to obtain an information about temperature and velocity of airflow with high accuracy. The thermo-anemometer which consists of the cold-wire thermometer and the hot-wire anemometer is one of the method for simultaneous measurement of the temperature and the velocity with high time resolution. This measurement system has sufficient frequency characteristics and S/N ratio (DC~5 kHz, 60 dB) to measure high frequency components. In this laboratory, the research on improving the accuracy of compensation circuits mounted on the thermo-anemometer is conducted by using a Field Programmable Gate Array (FPGA). FPGA is a digital device whose internal logic circuits can be reconfigured by a user program.

The low-speed wind tunnel equipped with the thermal stratification generator having a coil heaters is able to form a stratified flow with a temperature difference about 100 K at $U=3.0$ m/s (test section 100×100 mm²). Buoyancy effect on a heat and momentum transfer is experimentally evaluated in a various thermally conditions.

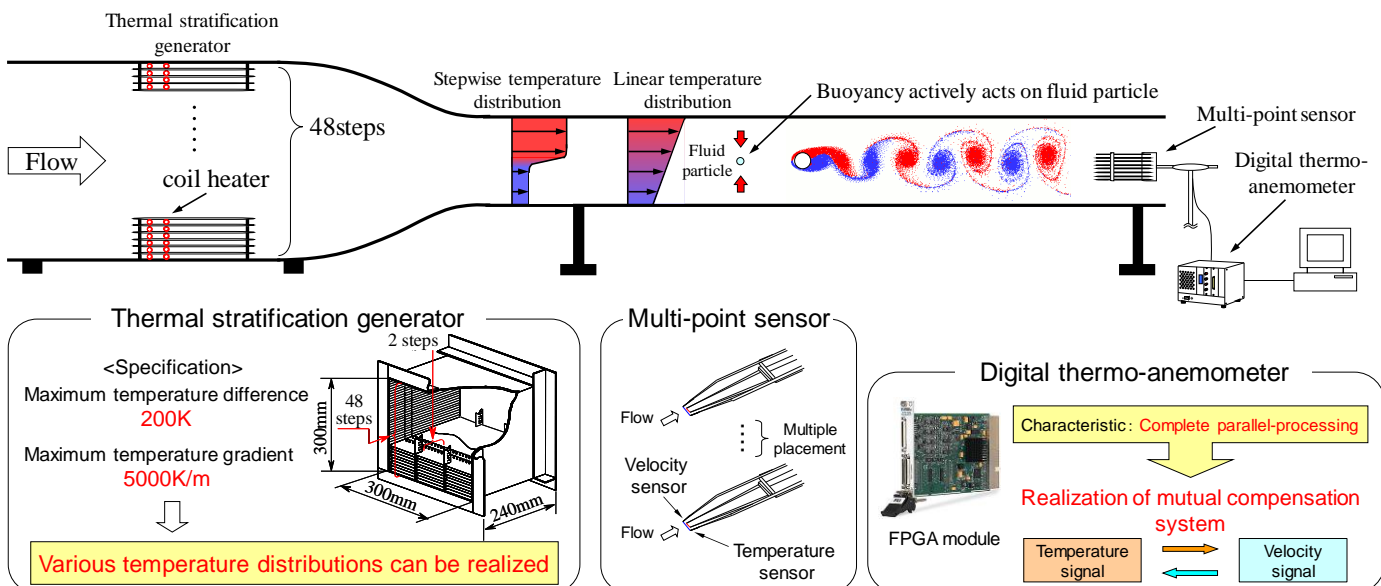

Development of Automated Patch-clamp System



Name	KOTANI Susumu	E-mail	kotani@numazu-ct.ac.jp
Job Title	Associate Professor	Degree	Ph. D.
Academic Society and Association	The Biophysical Society in Japan, The Society of Instrument and Control Engineer		
Research Keywords	Biomedical Engineering, bio-signal recording, electrophysiology		
Technical Fields and Topics possible for collaboration	<ul style="list-style-type: none"> Cell (primary, cell line) culture, transformation Intracellular calcium ion optical recoding Establish and maintenance of patch-clamp system Bio-signal recording, analysis 		

Details of the Research Theme

Selling Point: The machine automatically pushes the electrodes to the cells, even if you unfamiliar operate micromanipulator under the microscope.

Unlike cell suspensions, tissue sections maintain a network between cells, making it possible to examine the connections between cells. What functions and effects of expressed genes and when transplanting neurons derived from stem cells (eg, iPS cells) into the brain, the transplanted neurons and existing neurons When examining the relationship with the network, the patch clamp method using brain slices is suitable.

The slice patch clamp method was gold standard used by researchers specializing in physiology, but researchers in regenerative medicine and molecular biology are beginning to be interested in slice patch clamp as an effective research method .

However, this slice patch clamp device requires skill in micromanipulator operation, which can be called a craftsmanship, and is a barrier for researchers who want to introduce it as a new research method.

Therefore, we will try to automate the operation of micromanipulators by applying image recognition technology, and aim to develop a system that can be used with the same level of skill as microscopic observation.

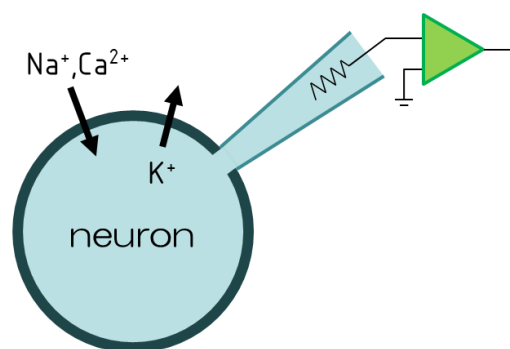
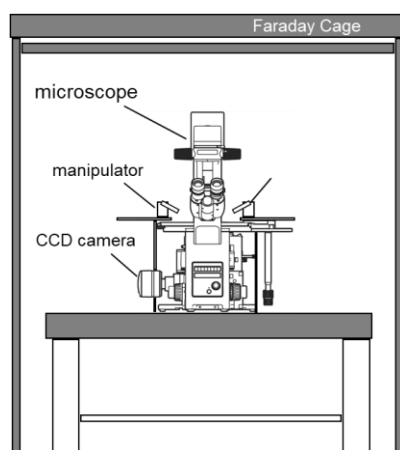

schema of patch-clamp

We have studied to improve cognitive decline with aging using animal brain tissue sections.

As the development of stem cell research, it has become necessary to confirm that neurons and cardiomyocytes derived from stem cells has the same properties as mature cells from normal development, not only in morphology but also in function. The patch clamp method used only by neurophysiologists is complicated to use. This complexity deters regenerative medicine researchers from using it. I would like to solve this problem by advantage of knowing the research experience.

Construction of Emergent medical support robot system



Name	AOKI Yusuke	E-mail	y.aoki@numazu-ct.ac.jp
Job Title	Associate professor	Degree	Master of Engineering
Academic Society and Association	The Robotics Society of Japan The Japan Society of Mechanical Engineers		
Research Keywords	medical robotics, social implementation robotics, robotic-echography		
Technical Fields and Topics possible for collaboration	<ul style="list-style-type: none"> ▪ Manipulator design / production / control ▪ Construction of hybrid control system of position / force / image control ▪ Skilled technique analysis using motion capture system ▪ Biological signal measurement 		

Details of the Research Theme

Ultrasound diagnosis support robot to reduce doctor's burden

I have constructed a robot system that reduces the burden on both examiners and patients in ultrasound diagnosis.

Diagnostic support systems that substitute ultrasound probe scanning technology by a robot have attracted attention. Ultrasound diagnostic support robot systems realize more precise probe positioning as well as application for tele-echography examination for isolated islands and doctorless villages, automatic inspection by robot alone, and training of inexperienced examiners, etc. Therefore, ultrasound diagnostic support robots for various organs have been developed in many institutions in Japan and abroad.

This study was carried out to realize an emergent medical support robot system that reduces the physical and mental burden of not only patients but also doctors and laboratory technicians.

In this study, we have developed a serial link-type robotic echography for a diagnostic and therapeutic system that can cope with lateral position diagnosis. Next, we evaluated the mental rotation ability potentially possessed by physicians and laboratory technicians in ultrasound diagnosis. Analyzing unique techniques used by experts and quantitatively indicating the mental rotation ability will expose problems faced by inexperienced examiners and lead to support for reducing the burden on doctors.

Next, with the experimenter cooperating with the robot, an experiment was conducted to calculate an intention estimation matrix that measures the direction and size of the probe scan intended by the inspector. As a result, regardless of the positional relationship between the robot and the experimenter, we succeeded in estimating the intention of the probe scan of the experimenter.



Fig.1 Robotic-echography system

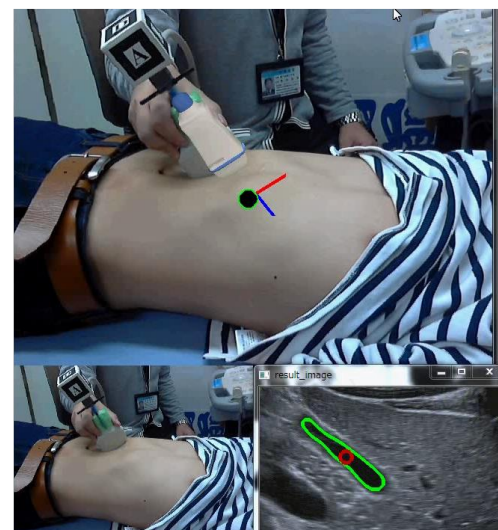

Fig.2 Estimation of organ shape by echogram processing

Evaluation of High Field Dielectric Properties of Polymer Insulating Material



Name	TOHYAMA Kazuyuki	E-mail	tohyama@numazu-ct.ac.jp
Job Title	Professor	Degree	Doctor (Engineering)
Academic Society and Association	IEEJ, IEEE, JSEE		
Research Keywords	High Field, Insulating Material, Electroluminescence		
Technical Fields and Topics possible for collaboration	<ul style="list-style-type: none"> Observation of Dissipation Current Waveform and Electroluminescence for Various Kinds of Polymeric Insulation Sheet under AC High Field. Evaluation of Inception and Extinction Electric Field of Partial Discharge for Various Kinds of Polymeric Insulation Sheet. 		

Details of the Research Theme

It is possible to evaluate the high field dielectric properties under AC high field with high accuracy by using our equipment.

■ ■ ■ Dissipation current waveform observed by Displacement Current Bypassing Method. ■ ■ ■

<Principle>

Over 99 % of the total current flows the insulator is a displacement current. In order to detect the quite small conduction current which include harmonic component, an inversed displacement current is applied to the shunt resistor. As the results of an inversed displacement current application, only the conduction current component flows the detecting resistor and its signal is observed.

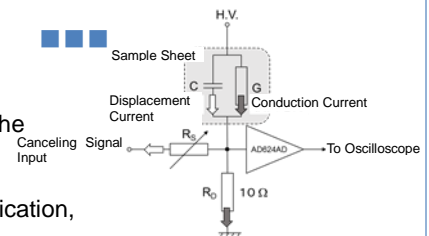

Fig.1 Detect Circuit

(Displacement Current Bypassing Method)

<Sample and Conditions>

Sheet sample size is 60 mm × 60 mm, and its thickness is around 0.1 - 0.2 mm. 3 terminal-electrode system is formed on both side of sample sheet by the gold evaporation in vacuum. Maximum applied voltage is 14.0 kV. Though the maximum frequency depends on the sample capacitance, it is around 10 - 400 Hz.

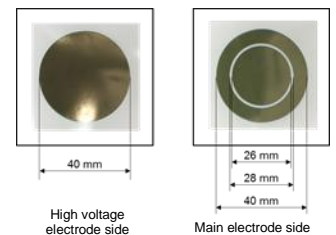

Fig. 2 Film's Geometry

(3-terminal electrode system)

■ ■ ■ Electroluminescence (EL) observed by Photo Multiplier Tube (PMT). ■ ■ ■

<What is EL?>

“Dissipation current waveforms” give the information about the charge movement in the insulator. On the other hand, “EL” gives the information of energy between the conduction level and the impurity level. The Head-On Type PMT (R943-02/ Hamamatsu) is photon counting type PMT. Its head size is 2 inch and it observe the visible light which wavelength from 200 to 800 nm.

<Why is PMT used for EL observation?>

EL is the luminescence which principle is same as LED. But, as its intensity is extremely weak luminescence phenomena compared to the light of LED, very sensitive and high accurate photo sensor PMT is used for this observation. As the enough positive and negative charges are supplied into insulator under high field and those charges are recombined, the EL will be observed. From the information about the applied field, the timing, the distribution of EL wavelength, it is possible to consider the conduction mechanism of a polymeric sheet under AC high field.

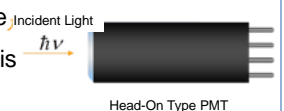

Head-On Type PMT